

# The ultimate WOW factor!

*Yes, this really is plastered over!...*

## The Product

The advent of high power vibrational element flat panel loudspeakers has given birth to the truly unseen loudspeaker. This plastered in-wall (or in-ceiling) product type reproduces high definition sound with zero visual interference to room aesthetics. Entertainment systems can now be employed in every room of the home, whilst avoiding all the usual techno clutter. This technology has the additional advantage of improved dispersion characteristics over a conventional loudspeaker, making speaker location and listening position much more flexible.

The width of an AIW product allows it to fit well within the 400mm between centre spacing commonly used in modern wood or metal studwork construction methods. However, if you have an unusual structure, Amina can provide installation advice and special sizes.

## Applications

The AIW1 is an affordable, concealed sound source for use in all parts of the home where more modest sound levels are called for. From bedrooms and bathrooms to kitchens and hallways, it reproduces high quality audio without compromising style or design.

The AIW3 is for use in all parts of the home including the main listening areas or home theatre, where good high levels of sound are required.

The AIW5 can be reserved for those special areas of the home, e.g. home theatre rooms, where very loud, highly dynamic, high performance reproduction is required.

In home theatre and other extended frequency range listening applications, the addition of a sub woofer to your system is recommended.

For those with monster taste in music or movie loudness, simply apply more than one AIW5 per channel.



SPECIFICATIONS	AIW1	AIW3	AIW5
Nominal impedance	8 ohms	4 ohms	8 ohms
Power handling: Continuous	20w	40w	80w
Sensitivity (with 1.5mm plaster skim)	82dB 1m/1w	84dB 1m/1w	87dB 1m/1w
Maximum SPL (with 1.5mm plaster skim)	95dB 1m/20w	99dB 1m/40w	105dB 1m/80w
Frequency range	100Hz to 20KHz	100Hz to 20KHz	100Hz to 20KHz
Electrical connection	Butt splice crimp or 2 part polarised connector		
Dimensions	450 x 345 x 40 mm	450 x 345 x 40 mm	450 x 345 x 40 mm
Product weight	910g	1175g	1810g
Minimum aperture depth	60mm from front of panel		
Fixings provided	Suitable for 12.5mm thick Plasterboard		
Box quantity	Pairs	Pairs	Pairs
High pass filter requirement	100Hz at 24dB/Octave (Minimum external required e.g. Amina AF2 active filter)		

For the very best results, your system electronics should also comprise in-line equalisation to compensate for slight variations in frequency response due to plaster depths and wall types.

*If you thought having great sound in the bedroom would be overpowering, think again!*

**amina**  
TECHNOLOGIES Ltd

**amina**  
TECHNOLOGIES Ltd

Amina Technologies Ltd is one of the world's leading designers and manufacturers of bespoke flat panel loudspeaker systems. We supply high definition sound solutions for voice reinforcement and live music reproduction in the professional audio industry, and for high performance audio systems in the home. From boardroom AV systems to Broadway theatres, from centres of worship to museums of work and war (Jersey) and from the film set of Phantom of the Opera (Pinewood Studios, London) to the film showing in your home cinema, Amina has the discreet audio solution for architects, interior designers and all design conscious clients. See our web site for more details on the company and some of the prestigious projects that use our products.

## Plaster-In-Wall Loudspeakers

Concealed Audio Solutions with inspirational results

Amina Technologies Ltd  
Cirrus House, Glebe Road, Huntingdon, Cambridgeshire, England, PE29 7DX  
tel +44 1480 354390 fax +44 1480 356564  
email inspired@amina.co.uk web www.amina.co.uk



Contact Amina to arrange  
Free RIBA CPD Seminars

Distributed by:

www.smartfuture.co.uk  
Email: enquires@smartfuture.co.uk  
Smart Plus Ltd  
9 Rodmell Road, Seaford,  
East Sussex  
BN25 4EE  
Tel: 01323 899161

### Warranty

All Amina In-wall loudspeakers are guaranteed against defective workmanship for five years.

Under our policy of continuous improvement, we reserve the right to change specifications without prior notice. E&OA

Easi-fill is a trademark of British Gypsum Ltd  
Amina is a registered trademark of Amina Technologies Ltd  
SoundUnseen® is a registered trademark of Amina Technologies Ltd  
Document: AIW1 literature Revision 3.0  
Copyright, Amina Technologies Ltd, 2006

*If you thought  
sound in the  
kitchen was an  
FM radio,  
think again!*



*“sound has never looked so good....”*

SoundUnseen® high definition audio reproduction with zero visual impact

# SoundUnseen®

HIGH DEFINITION AUDIO REPRODUCTION WITH ZERO VISUAL IMPACT.



*If you thought you couldn't have great sound in the bathroom, think again!*



## Inspirational Interiors

One of the most striking houses in the North East of England, this period art deco property, situated on the outskirts of Harrogate, has recently been transformed into one of the most desirable properties in the UK. With large open plan living spaces, the interior incorporates the very latest audio-visual, communication and entertainment systems, together with home automation and environmental control functions. The overriding emphasis, from a visual point of view, is of clean contemporary lines, no fuss and minimal technological impact, to create a stunning interior design.

Installed by Lifestyle Technologies of Yarm, the client selected the Amina SoundUnseen® Plaster In-Wall Loudspeakers in a 5.1 surround configuration to work alongside the two, centrally located plasma screens. The location of the full height two storey windows, with magnificent views of the garden, limits wall space and restricts the front left and right channel loudspeaker positions to a very small area immediately adjacent to the side walls.



*If you thought you needed to see numerous loudspeakers to have home theatre, think again!*

## The Conventional Solution

Well outside the main listening area, conventional in-wall loudspeakers (complete with visible meshed grilles), positioned here, generate a compromised sound quality due to the immediate reflections of acoustic energy from the side walls. Such reflected energy combines and interferes with the direct energy from the loudspeaker with resulting strange acoustic effects.

Their physical position also means that the main listening area receives less effective off-axis energy, resulting in poor frequency response and limited coverage. Overall the audio quality is poor, with steep and patchy sound level gradients evident within the large open plan space. By the kitchen, for instance, the reproduced sound level is very loud from one channel, but much quieter in the central area.

In conclusion, the system fails to achieve high quality surround sound at any point in the room due to the enormous width compared to its smaller depth.

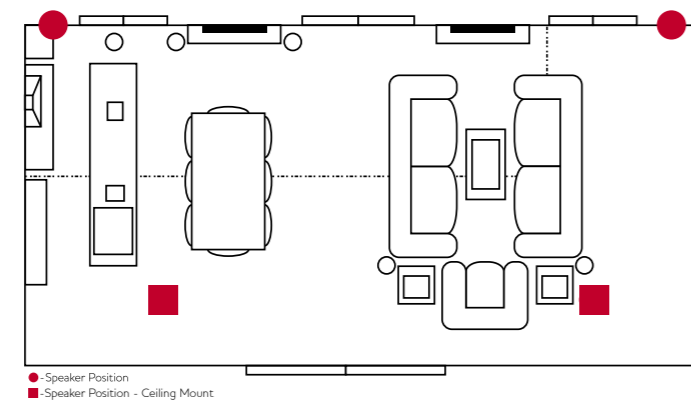

## The SoundUnseen® Solution

Now position Amina SoundUnseen® Plaster In-wall loudspeakers in the same place. Not only do all visual signs of a sound source completely disappear, but the resulting audio quality is astonishing. This is an excellent example of the freedom and flexibility now available to independently position the loudspeaker from the listener. The entire room is filled with high definition surround sound with no more steep sound pressure gradients, whilst the interior is left to be inspirational.

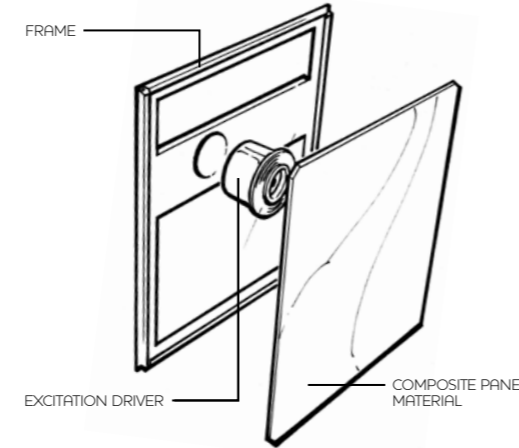

## The Technology

The core element of an Amina Plaster In-wall loudspeaker comprises a specialist lightweight, yet very strong composite panel material, which vibrates in the same way as the bodies of natural musical instruments (for example the acoustic guitar, violin or piano). These vibrations recreate a diffuse source of sound energy which is emitted in a far less directional manner and one capable of filling a space far more evenly than a conventional loudspeaker. This diffuse source creates a high definition sound field over a very wide area ensuring that surround sound or a stereo sound field is heard whatever the room, and wherever the listening position.

The beating heart of an Amina Plaster In-wall loudspeaker is its acoustic 'engine', using the very latest rare earth magnet based, high power vibrational excitation driver(s) (one in the case of the AIW1, and four in the case of the AIW5). This allows the AIW5 to handle an incredible 80w of continuous power, generating a massive 105dB of sound with plaster applied. The AIW range copes with the most dynamic of sounds, recreating the clarity of individual notes produced by the classical guitar, to the impressive effects generated in modern action movies.

The acoustic engine sets up tiny, but powerful vibrations (you can feel them but cannot see them) in the specialist composite panel material, which are then transferred through the plaster, paint or wallpaper to the very front surface of the wall or ceiling. This in turn vibrates air molecules at its boundary, which then excites more air molecules further away, sending a diffuse, non correlated energy sound wave out into the room.



## Wet Areas

Another great example of how SoundUnseen® technology helps achieve the best audio in a difficult space, both acoustically and environmentally, is evident in the swimming pool, hot tub area or bathroom.

Wet interior environments create two major challenges. The first is acoustic. In most wet areas, the humidity prevents us from having soft furnishings. This leaves us with hard ceramic floors, walls, ceilings, windows and the water itself. All these surfaces act as highly effective mirrors to acoustic energy. As we have all experienced, any noise made in a pool environment tends to echo for a substantial time, creating a general cacophony of sound.

The second problem is the general environmental conditions. The space is saturated with humidity filled with oxidising chemicals designed to keep the pool germ free. This aggressive compound quickly corrodes metal parts and even attacks man-made rubbers and adhesives. Conventional loudspeakers specified for pool use have to be very robust in order to survive, which generally means sound quality is compromised.

The Amina SoundUnseen® In-wall loudspeaker offers a solution to both problems. Once the unit is plastered into the wall structure, the plaster and the coatings applied to it (e.g. paint) isolate the product from any humidity, eliminating corrosion problems. Secondly, the energy wave produced by this technology is not directional and far less phase oriented. Sound reflected from surfaces interacts in a more positive manner. The result, especially with modest volume levels, will be intelligible, crystal clear audio reproduction, at an even level across the space. (It's worth noting that this energy cannot overcome the laws of physics – if sound is played very loud, then the cacophony will become more evident). Again not only have we now got excellent sound, we have no visible sound source to clutter decoration lines and no corrosion or degradation issues.

# Simple to Install...

IN NEW BUILD OR RETROFIT APPLICATIONS, SIMPLY FOLLOW THE STEP-BY-STEP INSTALLATION GUIDE BELOW:

## Installing in stud wall sections and in ceilings

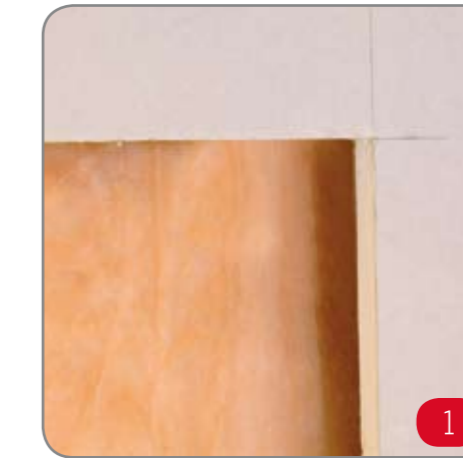

1 Create aperture using a sharp knife, making a series of shallow cuts. Add sound insulation into cavity.



2 Position installation lugs under top and bottom corners of surrounding plasterboard. Ensure cables are pulled to this position.



3 Fix installation lugs using two drywall screws secured through the front of the plasterboard into the plastic lug.



4 Position product in aperture. Connect loudspeaker to cable and test its operation.

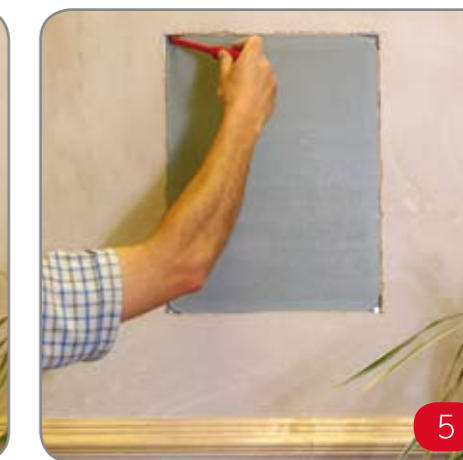

5 Secure product in place with one drywall screw through each corner of product. Adjust screws to ensure panel is flush with wall.

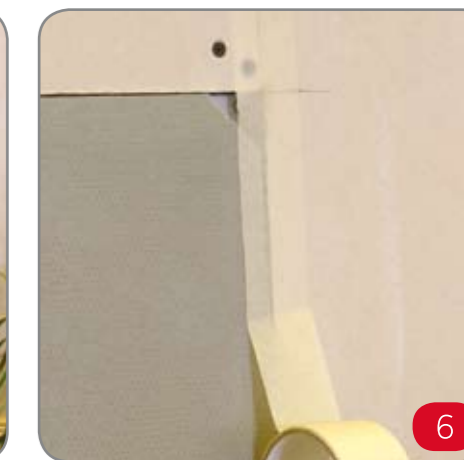

6 Apply joint tape, covering joint between panel and plasterboard. Perform final electrical/audio test.



7 For drywall applications only, set panel back 1mm to 2mm from front wall. Fill joint and skim surface with Easi-fill lightweight repair plaster.



8 Skim with plaster (ordinary multifinish is fine). The best finish is produced when the entire wall is skimmed at the same time.



9 Allow plaster to dry thoroughly before using and before decorating with paint or wallpaper.



## Installing in solid walls

For block and solid wall structures, create a 75mm aperture and embed the Amina AIW Backbox ready for fitting the loudspeaker prior to plastering.